

THE PTFE POPPET VALVE PRINCIPLE

The birth of the NR design of PTFE poppet valve was the brain child of Akos Sule the President of NR. He had the simple idea of producing a valve with the minimum of parts to assemble. The idea was to incorporate all the loose parts that other engineers seemed happy to design into their valves, and produce a one-piece poppet, diaphragm and seal. To that end Akos met his goal, having only two parts in a 2-way valve and three in a 3-way valve.

That is not to say that it was easy, as techniques had to be developed to accomplish the very accurate machining required to perform such a task. All NR poppet diaphragms are machined from solid PTFE rod to extremely fine limits with diaphragms being only a few thousandths of an inch thick.

DIAPHRAGMS - GENERAL APPEARANCE

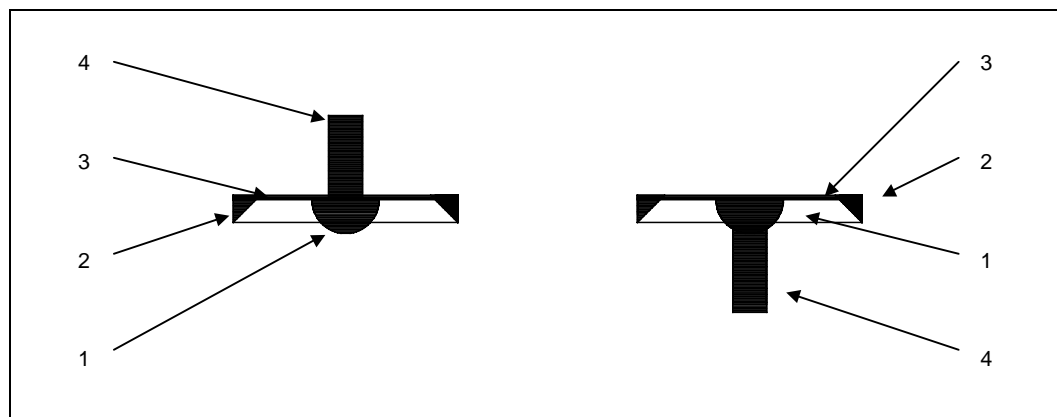

The diaphragms are made up of four main constituent parts as follows :-

1. The hemispherical poppet.
2. The outer sealing ring.
3. The centralising and sealing diaphragm.
4. The stem.

The hemispherical poppet is the plug which seals off the flow through the seat of the valve body. The reason for this design may not be immediately obvious, but, think of the poppet as a golf ball, and the seat as the neck of a milk bottle. No matter how you place the ball onto the neck of the bottle it will always centralise itself and sit down in the centre.

The outer sealing ring has a male angular leading edge, which when it is presented to its female counterpart in the valve body does two things, one, it slides down into the cavity tensioning and centralising the diaphragm, and two, seals the valve externally.

The diaphragm works as a sealing membrane with the outer sealing ring, but also supports and centralises the poppet in the seating area.

Stems come in two distinctive forms, the one on the left is for pulling or pushing via direct coupling to the armature of the solenoid. The other form on the right is the version used in 3-way valves where stems of two similar diaphragms are used to maintain a fixed distance between the

poppets, there by only allowing one to seat at a time. (This will be explained fully in the next section.)

As you can see a lot of thought had to go into the design of the final product to cover the multitude of functions required from it. It is this unique piece of engineering that sets NR apart from other companies is this field of valve technology.

BASIC CONFIGURATIONS FOR POPPET VALVES

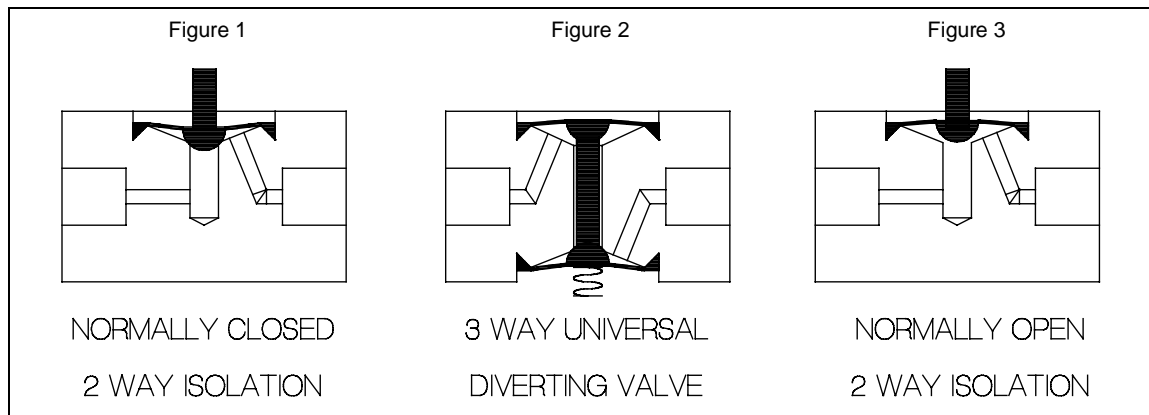

The poppet valves come in three main configurations, these are :-

1. 2 - Way normally closed.
2. 2 - Way normally open.
3. 3 - Way diverting.

1. 2 - Way normally closed. (Figure 1.)

The hemispherical poppet is seated into the central cavity of the valve by an external force on the top of the valve stem. This breaks the flow path between the two ports shown.

2. 2 - Way normally open. (Figure 3.)

The hemispherical poppet is un-seated from the central cavity of the valve by an external force pulling on the top of the valve stem. This allows flow path between the two ports shown.

3. 3 - Way diverting. (Figure 2.)

This valve incorporates diaphragms with the internal stems to maintain the required clearance between the poppets. The bottom poppet as shown, is held closed using an external spring, and in doing so it also holds open the top poppet. When an external force is applied to the top diaphragm, this force is transmitted along the stems to the bottom poppet. When this happens, the top poppet will seat and the bottom poppet will open. Such is the switching nature of this design. One port however is not shown, that being the common port which is connected to the central cavity. (The common

port is in the central plane and as such can not be seen.) With the switching action of this valve, the common port will be connected to which ever poppet is open at the time.

The top port, (normally open), when de-energised, the bottom port, (normally closed), when energised.

EXAMPLE ASSEMBLIES

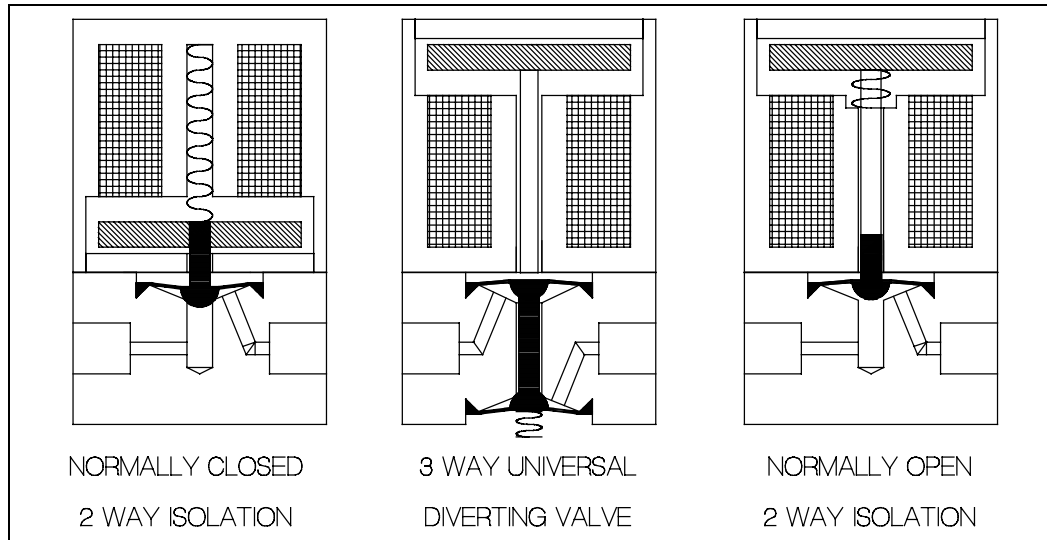

As you can see from the above diagram we have now incorporated the solenoid actuators with the relevant valve, pulling on the normally closed, pushing on the 3-way, and pushing with spring assisted opening on the normally open.

The three basic concepts given above are the basis for all the range of NR PTFE solenoid valves, be it a single valve body, multi-valves or manifolds. There is one slight variation that is also available, though this is a special which we refer to as the "Quick Flush" type valve.

QUICK FLUSH VALVE

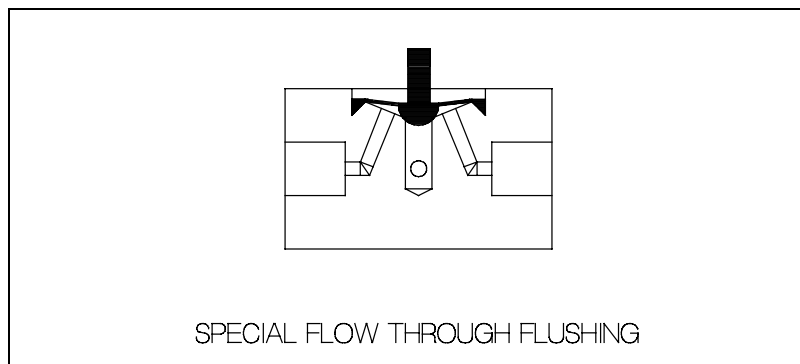

This type of valve is based on the 2-way but introduces an extra port into the diaphragm cavity. This allows the possibility to either flush the internals of the valve in-situ, inject a medium into an existing flow, or simply take samples from a flow.

More detailed coverage of this concept and others will be discussed by contacting one of our offices either in the USA or Europe.